

Champion®

POWER



7.5KW INVERTER GENERATOR MODEL NO: IG8000

PART NO: 8877135

OPERATION & MAINTENANCE INSTRUCTIONS

UK
CA | CE



ORIGINAL INSTRUCTIONS

DL0924 Rev 1

INTRODUCTION

Thank you for purchasing this CLARKE Generator.

Before attempting to operate the machine, it is essential that you read this manual thoroughly and carefully follow all instructions given. In doing so you will ensure the safety of yourself and that of others around you, and you can also look forward to the product giving you long and satisfactory service.

Ensure the generator and its components suffered no damage during transit and that all components are present. Should any loss or damage be apparent, please contact your CLARKE dealer immediately.

GUARANTEE

This CLARKE product is guaranteed against faulty manufacture for a period of 12 months from the date of purchase. Please keep your receipt as proof of purchase.

This guarantee is invalid if the product is found to have been abused or tampered with in any way, or not used for the purpose for which it was intended.

Faulty goods should be returned to their place of purchase, no product can be returned to us without prior permission.

This guarantee does not effect your statutory rights.

GENERAL SAFETY RULES & SYMBOLS











⚠ DANGER

Using a generator indoors **WILL KILL YOU IN MINUTES.**
Exhaust contains carbon monoxide, a poison gas you cannot see or smell.

 <p style="text-align: center;">NEVER use in the home or in partly enclosed areas such as garages.</p>	 <p style="text-align: center;">Only use OUTSIDE and far from open windows, doors, and vents.</p>
--	--

**Avoid other generator hazards.
READ MANUAL BEFORE USE.**

SAFETY SYMBOLS

	Read Instruction manual before use		DANGER - highly flammable liquid.
	Caution - The user should be aware of a general hazard		Engine and exhaust become hot during use - DO NOT touch
	Dangerous voltage. Risk of electric shock		Poisonous fumes - DO NOT use in an enclosed space.
	Wear ear defenders		Wear protective gloves.
	Wear a protective facemask.		WARNING: Loud noise.
	DO NOT use in rain, snow or damp conditions.		

WORK AREA

1. **ALWAYS** use in a well ventilated area.
2. **ALWAYS** position the exhaust outlet away from people.
3. **NEVER** use indoors or in a confined space.
4. **ALWAYS** keep children away from the generator.

POSITIONING THE GENERATOR

1. **ALWAYS** leave a least a 1m gap between the generator and any surrounding building or structures.
2. **ALWAYS** ensure the generator is on a dry, solid, level and flat surface.
3. **ALWAYS** ensure the surrounding area is free from any material that could burn or be damaged by heat.
4. **NEVER** move or tilt the generator whilst it is switched on.

FIRE PREVENTION

1. **ALWAYS** switch the engine OFF when refuelling. Allow generator to cool for at least 2 minutes before removing the fuel cap. Loosen cap slowly to relieve pressure in the tank.
2. **ALWAYS** refuel away from any source of heat.
3. **ALWAYS** refuel in a well ventilated area.
4. **ONLY** use standard unleaded petrol.
5. **DO NOT** overfill the fuel tank. **DO NOT** fill to the very top of the tank and leave room for petrol expansion.
6. **NEVER** smoke whilst refuelling and avoid smoking or using a naked flame near the generator.
7. **DO NOT** operate near an open flame, heat or flammable materials. This generator may emit highly flammable and explosive petrol vapours.
8. **NEVER** start the engine if there is spilled fuel. Any spillage must be wiped clean and the generator allowed to dry before attempting to start the engine.

PREVENTION OF ELECTRIC SHOCK

1. **NEVER** use the generator in wet conditions unless it is well protected/covered. Under these conditions, adequate ventilation **MUST** be provided.
2. **NEVER** operate the generator with wet hands.
3. **NEVER** use water or any other liquids to clean the generator.

4. **ALWAYS** ground the generator before using it to maximise safety, see 'Ground The Generator' section on pages 15.
5. **ALWAYS** use a ground fault circuit interrupter (GFCI) in highly conductive areas such as metal decking or steel work. Extension cords with an in-line GFCI are recommended for these operations.

ADDITIONAL SAFETY RULES FOR GENERATORS

1. **ALWAYS** ensure the applied load does not exceed the generator rating. Overloading the generator is dangerous and could cause damage.
2. **ALWAYS** disconnect and switch off the generator when carrying out any maintenance.
3. **ALWAYS** ensure the generator reaches operating speed before connecting a load.
4. **NEVER** allow the generator to run out of fuel when a load is connected.
5. **NEVER** transport the generator with fuel in the tank.
6. **DO NOT** connect to a commercial or residential power supply; e.g. ring main.
7. **DO NOT** touch hot parts. This generator produces heat when running. Temperatures near the exhaust can exceed 150°F/65°C. Allow the generator to cool down after use before touching the engine or areas of the generator that become hot during use.
8. If any part of the generator, electrical device or power cable is broken, damaged or defective, make sure it is repaired or replaced before using. Service or repair of the generator should only be performed by a qualified technician.
9. **NEVER** modify the generator in any way. Modifying or using the generator for any other purpose for which it is not designed may result in serious injury, machine damage and voiding of the warranty.
10. **ALWAYS** turn off all connected electrical devices before stopping the generator.
11. **ALWAYS** turn the engine switch to the 'OFF' position when the engine is not running.
12. **NEVER** carry or lift the generator using the handle assembly.

GENERATOR OVERVIEW

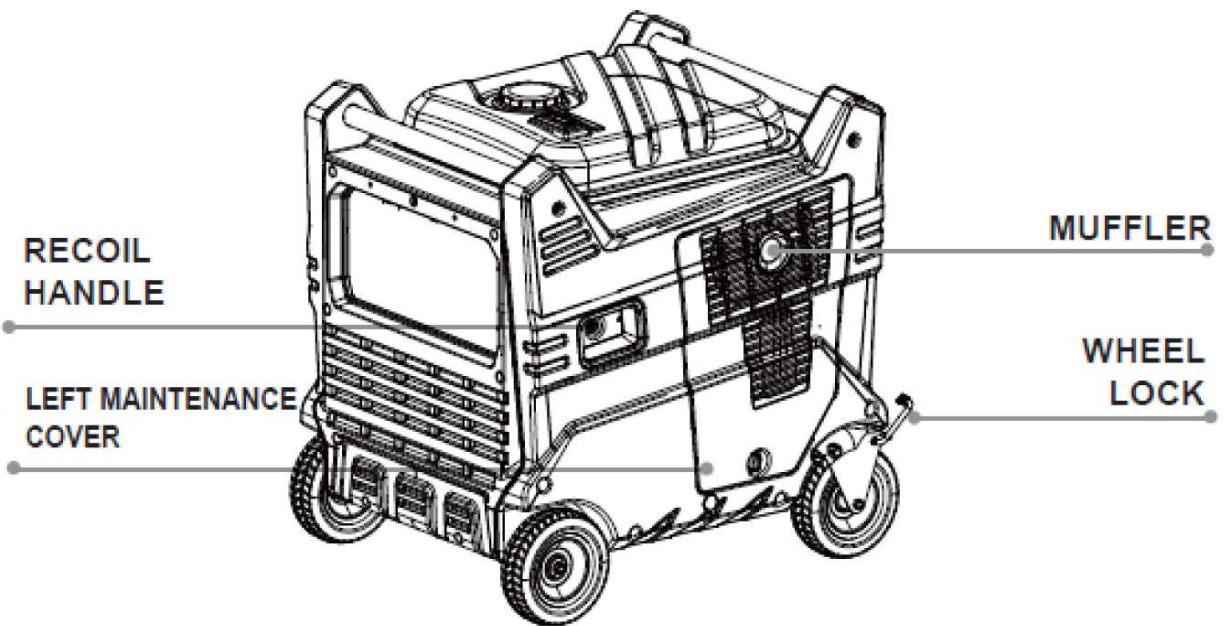
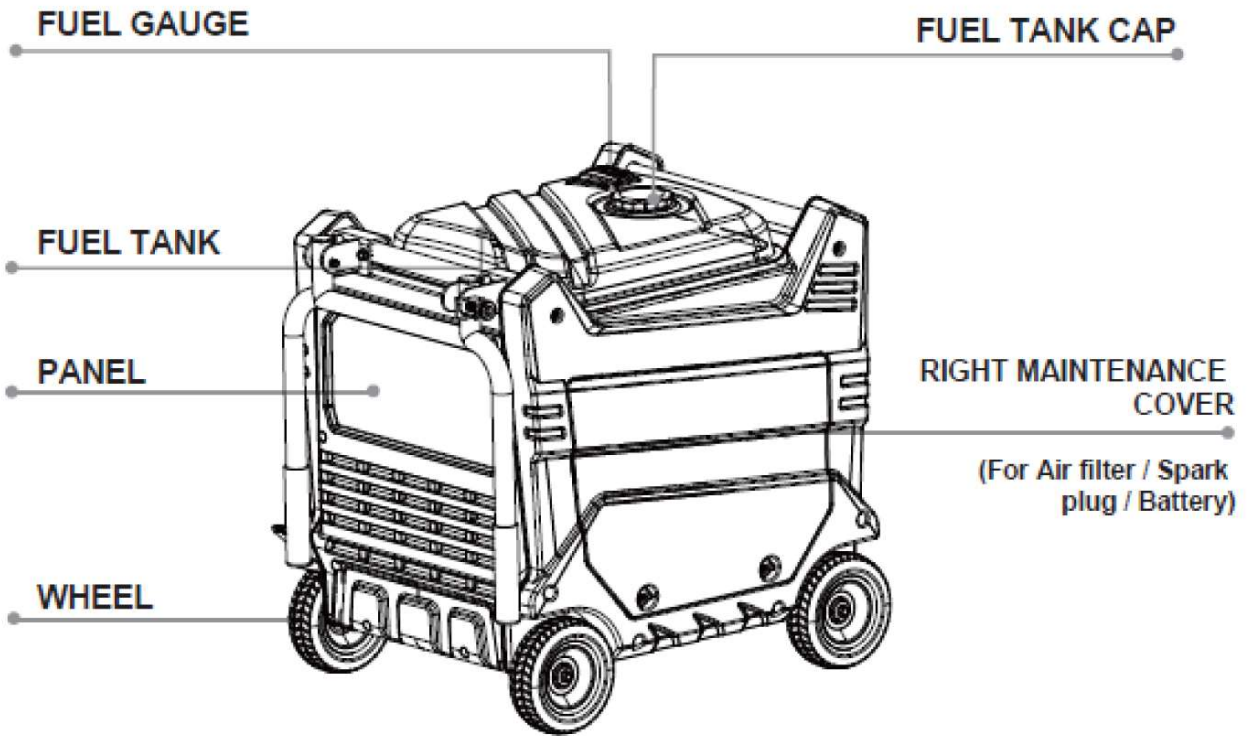

CONTROL PANEL OVERVIEW

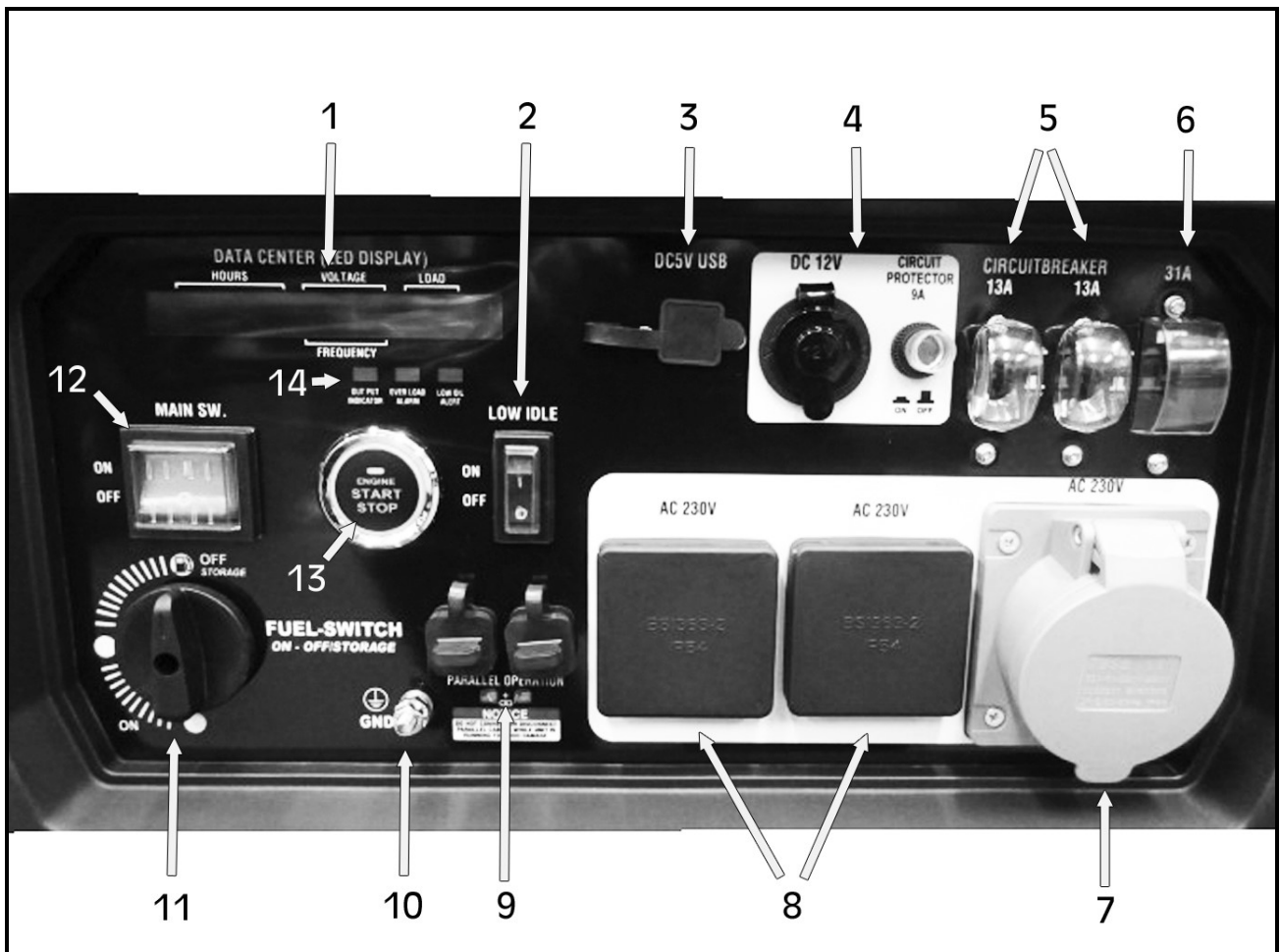

NO	DESCRIPTION	NO	DESCRIPTION
1	Fuel Gauge, Voltage & Load Display	8	13A, AC 230V 3 Pin Plug Outlets
2	Low Idle Switch	9	Parallel Operation Outlet
3	DC 5V USB Outlet	10	Ground Earthing Point
4	DC 12V Adaptor Outlet & 9A Circuit Protector	11	Fuel Switch
5	13A Circuit Breaker x 2	12	Main SW Switch ON/OFF Button
6	31A Circuit Breaker	13	Engine STOP/START Button
7	32A, AC 230V 3 Pin Plug Industrial Outlet	14	Output, Overload Alarm & Low Oil Alert Indicators

UNPACKING

Unpack your generator and check to ensure the following items are present. Should there be any deficiency or damage caused during transit contact your CLARKE dealer immediately.

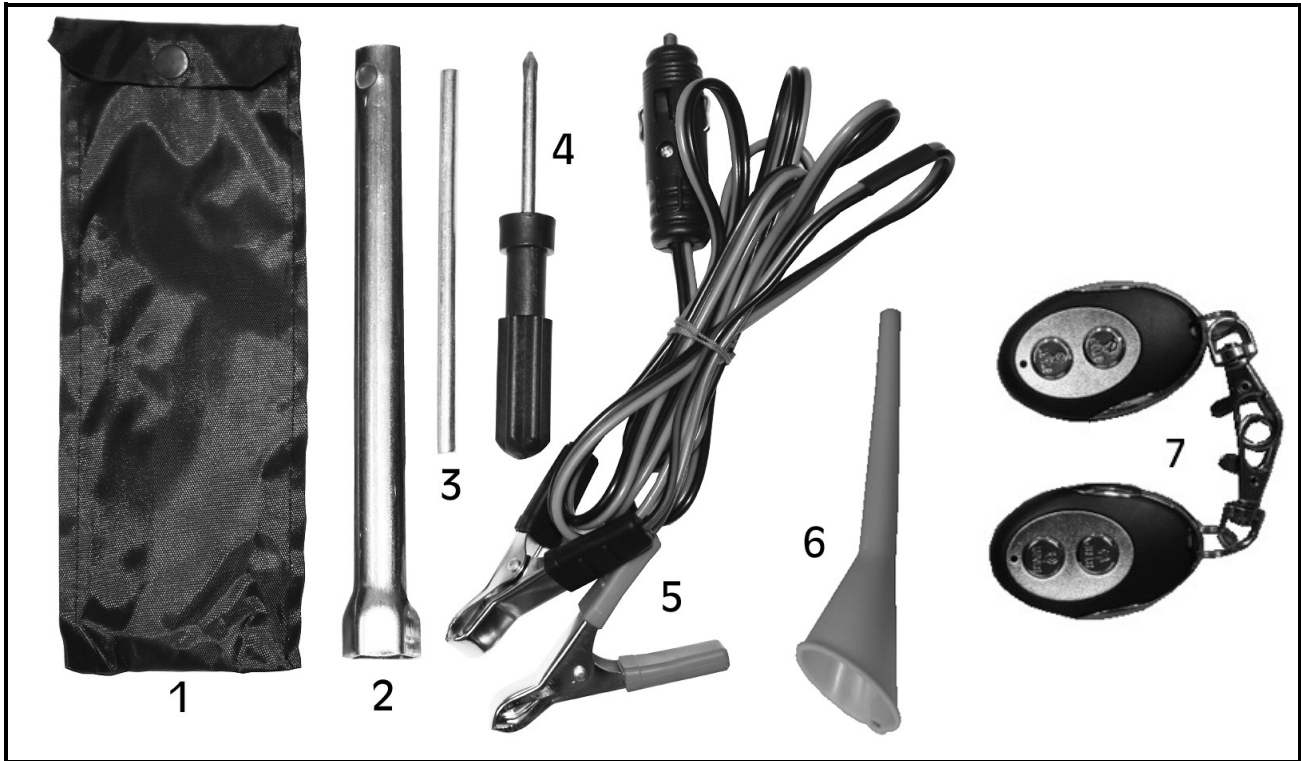

NO	DESCRIPTION	NO	DESCRIPTION
1	Tool Pouch	5	12 Volt D.C. output lead assembly with positive (red, '+') and negative (black '-') crocodile clips
2	Spark Plug Spanner	6	Oil Funnel
3	Spark Plug Spanner Arm	7	Remote Control x 2
4	Cross Head Screwdriver		

BEFORE USING THE GENERATOR

Before using your generator check that the generator is:

- In good condition and free from any damage.
- Clean and free from fuel or oil spillage.
- Correctly located for use.

KNOW YOUR GENERATOR

LOW IDLE

This generator is equipped with a low idle switch. Engaging this switch allows the system to regulate the engine speed and automatically adjust its fuel consumption to match the required load. When the electrical load changes, the generator engine will automatically speed up and slow down as needed. This reduces fuel consumption and noise levels, while extending runtime and the engines lifespan.

Keep this switch engaged (ON) only when the power load requirement is less than 75% of the rated watts. **DO NOT** engage the switch when the total load is more than 75% of rated watts. The generator engine must run at full speed to supply power for anything over 75% of rated watts.

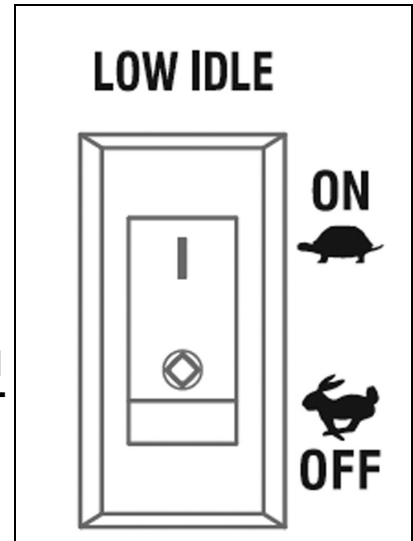

PARALLEL OPERATION

The parallel operation outlet allows you to connect two of these generators together to increase the total available electrical power. Follow the instructions included with the parallel operation kit for correct installation and operation.

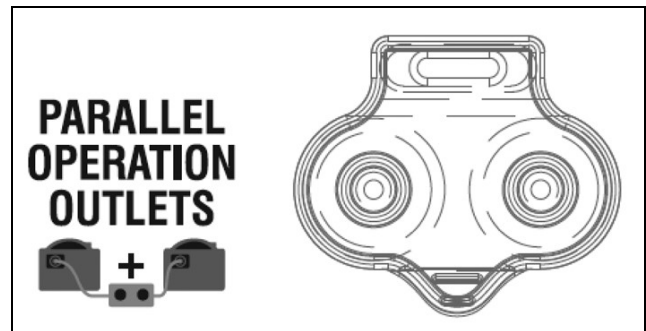

NOTE: The Parallel Operation Kit is not supplied with this generator. Contact your CLARKE dealer for more information.

CIRCUIT BREAKERS

The circuit breakers protect the individual AC and DC circuits. The AC circuit breaker will activate when the AC outlets exceed their maximum current. The DC circuit breaker will activate when the DC 12V and/or 5V USB outlet exceed their maximum current. When the circuit breaker activates, turn off and disconnect the device(s) from the respective outlets and press the circuit breaker to reset.

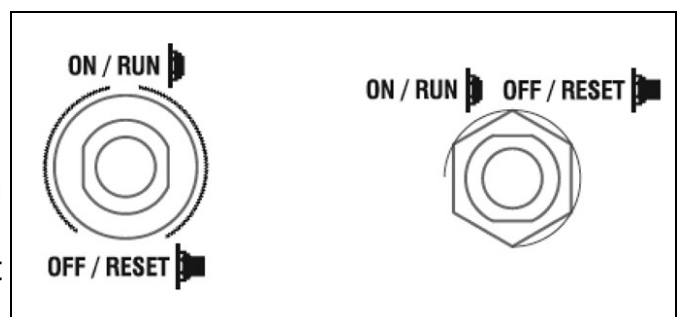

CONNECTING ELECTRICAL DEVICES

Follow the steps below to properly connect your device(s) to the generator.

1. Before connecting electrical devices, allow the generator to run for a few minutes to stabilise the speed and voltage output.
2. Select the device with the highest wattage and make sure it is turned off. Plug the device into the generator and then turn the device on. Allow the engine to stabilise.
3. Repeat step 2 to plug in each additional device. **DO NOT** attempt to plug in and start multiple devices at the same time.

GENERATOR CAPACITY

Make sure the generator can supply enough running (rated) and starting (max.) watts for the items you will power at the same time. Follow these simple steps.

1. Select the items you will power at the same time.
2. Total the running (rated) watts of these items. This is the amount of power the generator must produce to keep the items running.
3. Estimate how many starting (max.) watts you will need. Starting wattage is the short burst of power needed to start electric motor driven tools such as a circular saw or refrigerator. Because not all motors start at the same time, total starting (max.) watts can be estimated by adding only the items with the highest additional starting (max.) to the total rated watts.

Example:

Tool/Appliance	Running Watts	Additional Starting Watts
Refrigerator	700	1350
Portable Fan	40	120
Laptop	250	250
46 in. Flat Screen TV	190	190
Light (75 Watts)	75	75
	1255 Total Running Watts	1350 Highest Starting Watts

Total Running Watts: 1255
Highest Starting Watts: +1350
Total Starting Watts Needed = **2605**

NEVER add more loads than the generator capacity. Take special care to consider surge loads in generator capacity as previously described.

The chart below serves as a reference for the estimated wattage requirements of common electrical devices. however, **DO NOT** solely rely on this chart, all electronics and appliances are built differently, **ALWAYS** check the wattage listed on the electrical device before consulting this chart:

Tool/Appliance	Rated (Running) Watts	Surge (Starting) Watts
Hot Plate	2500	0
Saw - Circular	1500	1500
Saw - Mitre	1200	1200
Microwave	1000	0
Well Water Pump	1000	1000
Sump Pump	800	1200
RefrigeratorFreezer	800	1200
Computer	800	0
Television	500	0
Box Fan	300	600
Light Bulb	75	0

GENERATOR PREPARATION

STEP 1 - ADD/CHECK OIL

NOTE: THE GENERATOR IS SHIPPED WITHOUT OIL ADDED.

The user must add the proper amount of oil before operating the generator for the first time. The oil capacity of the engine crankcase is **1litre (35.2 fl.oz)**.

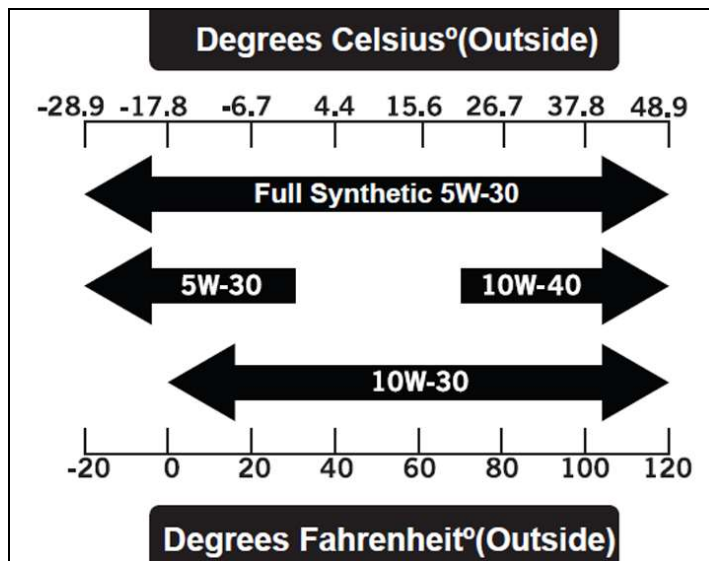

NOTE: Depending on outside working temperature, to find out which oil to use, consult the chart shown.

To add oil, follow these steps:

1. Place the generator on a level surface. Make sure the engine is OFF before adding or checking oil.
2. Loosen the screws on the left side access cover and remove the cover from the side panel as shown. Unscrew the yellow oil dipstick from the engine.

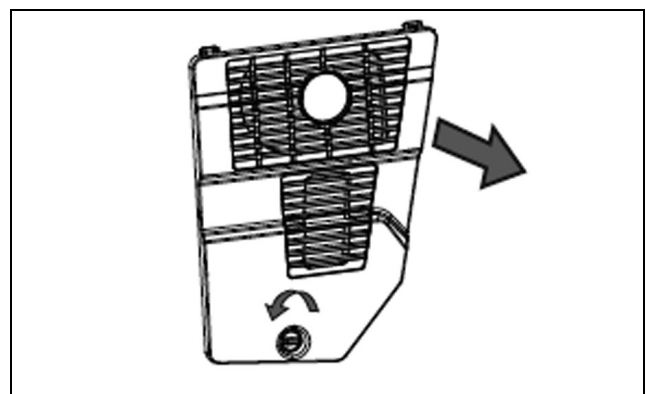

3. Using the oil funnel or appropriate dispenser, slowly add oil as shown, being careful not to overfill the unit. Fill the crankcase to the upper fill line so you can visually see the oil coming halfway up the oil fill threads.
4. Refit the oil dipstick and firmly tighten it. Wipe clean any spilled oil.

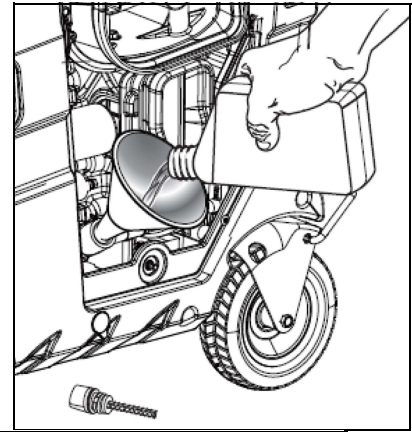

NOTE: Used engine oil should be disposed of at an approved disposal site. See local authority recycling for more information.

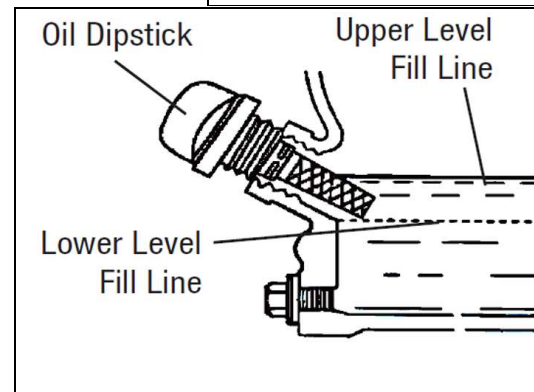

For subsequent operation, the oil level should be checked before each use, or after every 8 hours of operation. The generator is equipped with a low oil sensor and will not start without a sufficient amount of oil.

TO CHECK OIL LEVEL (BEFORE EVERY SUBSEQUENT START)

1. Place the generator on a level surface. Make sure the engine is OFF before adding or checking oil.
2. Open the oil access cover. Remove and wipe the dipstick with a clean rag.
3. Insert the dipstick into the oil fill without screwing it in. Remove the dipstick and check the oil mark.
4. If the oil mark covers less than one half of the dipstick, slowly add oil until the oil mark reaches to the top of the dipstick (or when you can see the oil coming halfway up the oil fill threads).
5. Wipe clean any oil leaks and firmly tighten the dipstick. Reinstall the oil access cover.

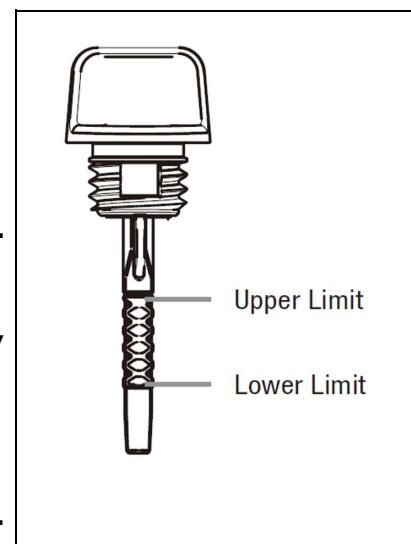

STEP 2 - ADD/CHECK FUEL

Use only fresh (within 30 days from purchase), lead-free petrol with a minimum of 87 (E10) octane rating. The generator performs best with ethanol-free petrol. **DO NOT** use petrol with over 10% ethanol. The capacity of the fuel tank is **26 Litres**

(5.7 gallons). DO NOT MIX OIL WITH THE PETROL.



WARNING: KEEP GENERATOR AWAY FROM OPEN FLAME. THIS GENERATOR MAY EMIT HIGHLY FLAMMABLE AND EXPLOSIVE PETROL VAPOUR, WHICH CAN CAUSE SEVERE BURNS OR EVEN DEATH IF IGNITED. A NEARBY OPEN FLAME CAN LEAD TO EXPLOSION EVEN IF NOT DIRECTLY IN CONTACT WITH THE PETROL.



WARNING: ENSURE THERE IS ADEQUATE FUEL IN THE TANK WHEN USING THE GENERATOR. RUNNING OUT OF FUEL OR STOPPING THE ENGINE SUDDENLY WITH A LOAD CONNECTED COULD CAUSE SERIOUS DAMAGE.

To add petrol, follow these steps:

1. Make sure the generator is shut OFF and on a level surface. Unscrew the fuel cap, as shown, and set it aside. The fuel cap may be tight and hard to unscrew.
2. Slowly add unleaded petrol to the fuel tank. Be careful not to overfill and only fill to the marked fill line on the fuel level indicator.

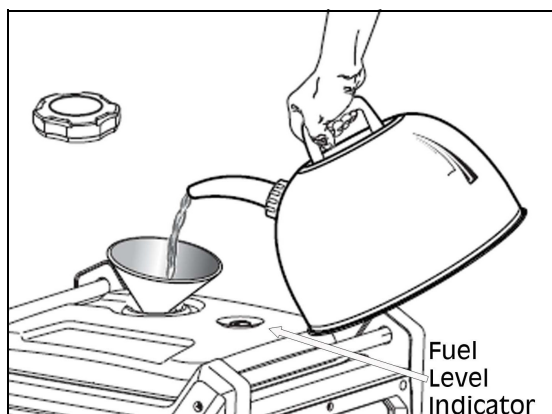

NOTE: DO NOT fill the fuel tank to the very top. If you do so, petrol will expand and spill during use, even with the fuel cap in place.

3. Reinstall the fuel cap and wipe clean any spilled petrol with a dry cloth.

NOTE: During operation, the fuel level will be displayed on the data centre of the control panel, or check the fuel gauge. If the fuel level is low, refill the fuel tank before starting your generator for the next time.

STEP 3 - CONNECT THE BATTERY



CAUTION: ALWAYS USE EYE PROTECTION WHEN HANDLING BATTERIES AND WASH YOURS HANDS AFTER HANDLING.

- Keep battery away from sparks, cigarettes or other sources of flame.
- Connect & disconnect battery only when generator is OFF and in well ventilated areas.
- Keep out of reach of children.

The generator is shipped with the lead acid battery's negative (black, '-')

terminal disconnected to maximise safety. To start the generator using the electric start, the battery must be connected.

To connect the battery, follow these steps:

1. Loosen the screws to the right side maintenance cover. Remove cover and set aside.

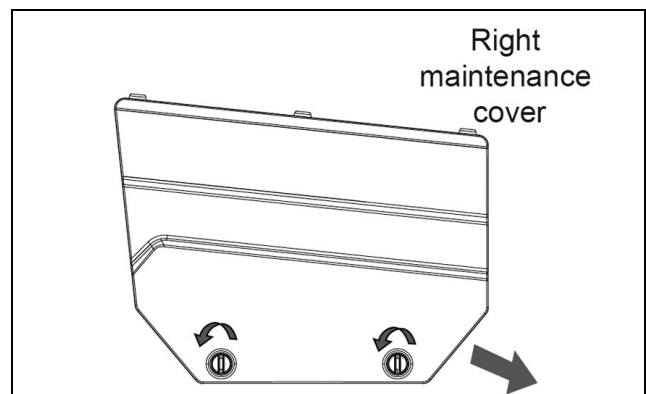

2. Connect the red wire to the positive (+) terminal first, then connect the black wire to the negative (-) terminal. Make sure all connections are tight.

NOTE: Be careful not to short across the terminals when installing. Shorting the terminals together can cause sparks, damage the battery and/or generator and can cause burns or explosions.

3. Reinstall and secure the maintenance cover.

NOTE: If you do not plan to use the generator for a long period of time, we recommend to disconnect the negative (black, '-') battery cable from the battery to protect the battery from losing charge. After disconnecting the cable, cover the free end with an insulator such as electrical tape. You may also choose to use a trickle charger (not included) to maintain battery charge.

STEP 4 - GROUND THE GENERATOR

To reduce the risk of electric shock and to maximise safety, the generator should be properly grounded.

Ground the generator by connecting a grounding wire to the grounding nut on the front control panel and tighten. A generally acceptable grounding wire is a No.14 SWG (Standard Wire Gauge) stranded copper wire.

This grounding wire should be connected at the other end to a copper, brass or steel grounding rod that is driven into the earth. Wire and grounding rods are not included with the generator.

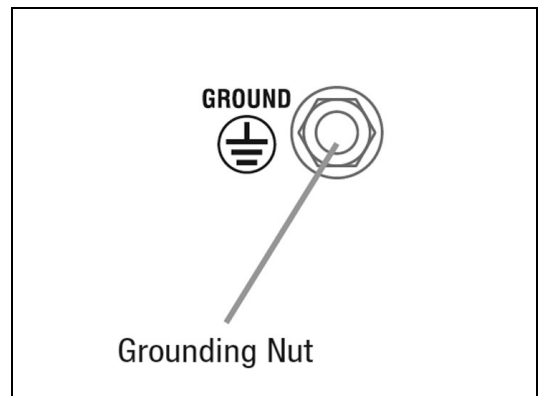

NOTE: Grounding codes can vary by location. Contact a local electrician to check the area codes.

STARTING YOUR GENERATOR

Before starting the generator, make sure you have read and performed the steps in the 'Generator Preparation' section (pages 12-15) of this manual.



WARNING: GENERATOR EXHAUST EMISSIONS CONTAINS CARBON MONOXIDE (CO). THIS IS A POISONOUS GAS YOU CANNOT SEE OR SMELL. IF YOU CAN SMELL THE GENERATOR EXHAUST, YOU ARE BREATHING IN CO GAS.

ALWAYS use a ground fault circuit interrupter (GFCI) in highly conductive areas such as metal decking or steel work. GFCI's are available in-line with some extension cables.

CAUTION: DISCONNECT ALL ELECTRICAL LOADS FROM THE GENERATOR BEFORE ATTEMPTING TO START.

BEFORE STARTING THE GENERATOR:

1. Verify that the generator is outside on a dry, level surface. Allow at least 1m of clearance on all sides of the generator.
2. To maximise safety, check that the generator is properly grounded (see above).
3. Check there is sufficient level of oil in the crankcase. Add oil if necessary.
4. Make sure there is sufficient level of petrol in the fuel tank. Add fuel if necessary, see pages 13-14.
5. Make sure all electrical devices are unplugged from the generator during ignition. Otherwise it will be difficult for the engine to start.

TO START THE GENERATOR, PERFORM THE FOLLOWING STEPS:

1. Turn the LOW IDLE MODE switch to the 'OFF' position.

NOTE: If you wish to use the Low Idle Mode, turn the switch to the 'ON' position after the engine has warmed up for 2 - 3 minutes.

2. Turn the MAIN SWITCH to the 'ON' position.
3. Turn the FUEL SWITCH to the 'ON' position as shown.

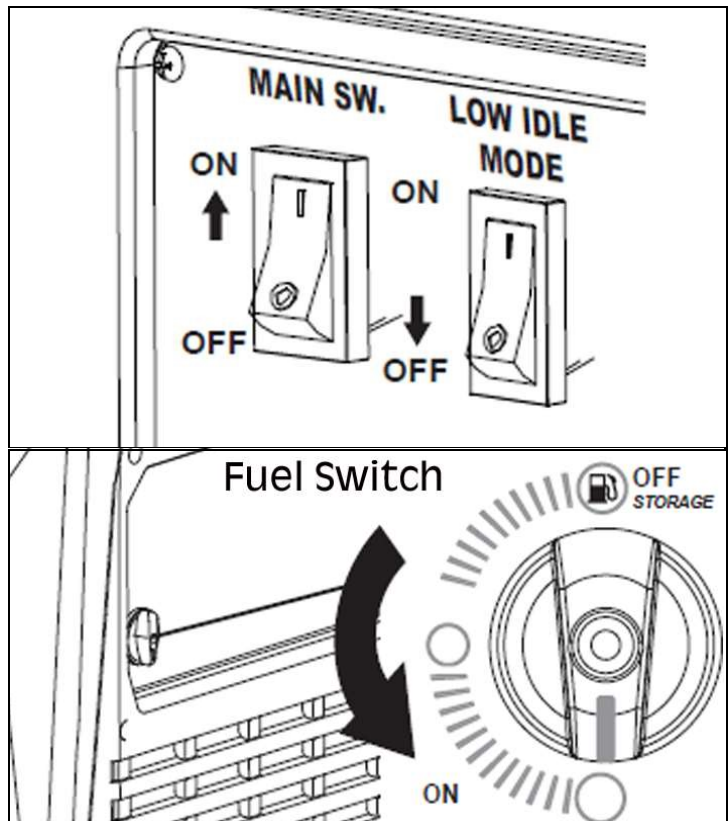

After completing steps 1 to 3, there are three ways to start the generator, either by Electric One Button Start, Remote Control or Manual Recoil Start, as follows:

ELECTRIC ONE BUTTON START & REMOTE CONTROL

1. Hold down the ENGINE START/STOP button for 5 seconds.

NOTE: If the engine does not start, release the button, wait 10 seconds and try again. Keeping the button compressed for too long can damage the starter.

NOTE: If you have repeated failed attempts to start the engine, please consult the troubleshooting guide on pages 28-29.

One-Button Start:



- Alternatively, hold down the ENGINE START button on the remote control for 5 seconds.



- Allow the generator to run for several minutes before attempting to connect any electrical devices. This allows the generator to stabilise its speed and temperature.

MANUAL RECOIL START

NOTE: Use the Recoil Starter when the battery voltage is too low to turn the starter motor.

- Pull the Starter Grip lightly until you feel resistance; then pull briskly in the direction of the arrow as shown.

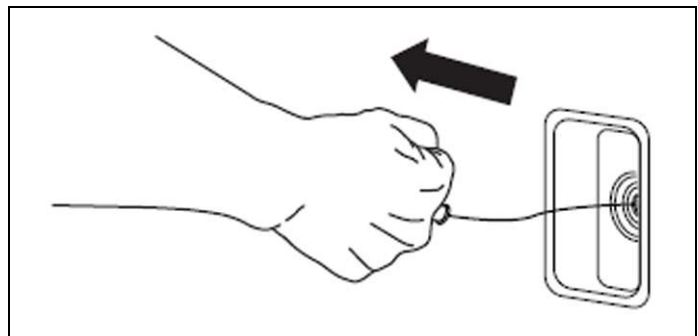

NOTE: DO NOT allow the grip to snap back after starting; return it gently to its original position.

- Allow the generator to run for several minutes before attempting to connect any electrical devices. This allows the generator to stabilise its speed and temperature.

SHUTTING OFF THE GENERATOR

WARNING: ALLOW THE GENERATOR TO COOL DOWN BEFORE TOUCHING AREAS THAT BECOME HOT DURING USE.

CAUTION: ALLOWING PETROL TO SIT IN THE FUEL TANK FOR LONG PERIODS OF TIME CAN MAKE IT DIFFICULT TO START THE GENERATOR IN THE FUTURE. NEVER STORE THE GENERATOR FOR EXTENDED PERIODS OF TIME (OVER 2 MONTHS) WITH FUEL IN THE TANK. REFER TO 'STORING THE GENERATOR' ON PAGE 25

- Turn off all electrical devices prior to unplugging them from the generator. Unplugging running devices can cause damage to the generator.

2. Allow the generator to run at no load for a few minutes to stabilise the internal temperature.
3. Turn the 'MAIN SWITCH' to the 'OFF' position.
4. Turn the FUEL switch to the 'OFF' position.

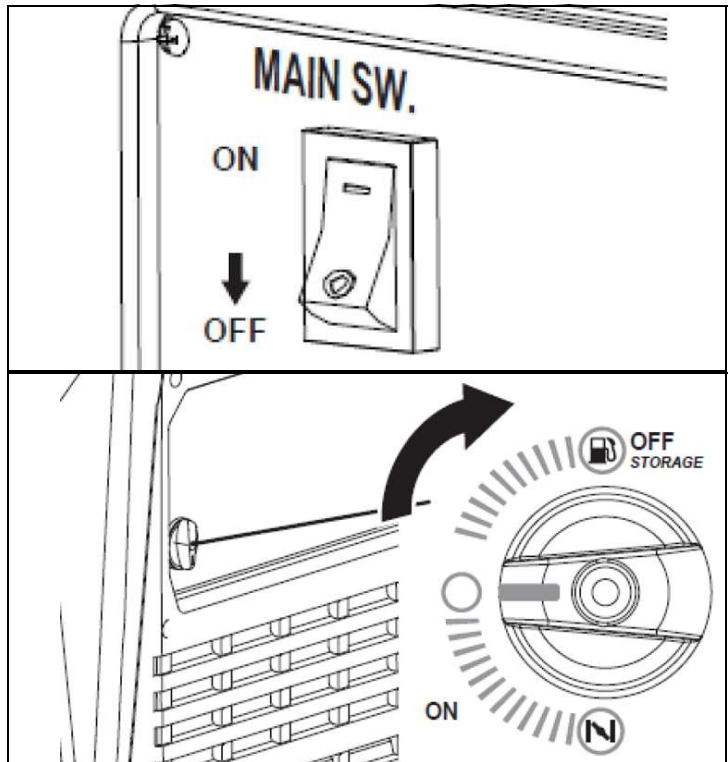

MAINTENANCE

Proper routine maintenance of the generator will help prolong the life of the machine. Please perform maintenance checks and operations according to the Maintenance Schedule below.

If there are any questions about the maintenance procedures listed in this manual, please contact the CLARKE service centre.



WARNING: NEVER PERFORM MAINTENANCE OPERATIONS WHILE THE GENERATOR IS RUNNING. BEFORE MAINTENANCE OR SERVICING THE GENERATOR, TURN OFF THE GENERATOR, DISCONNECT ALL DEVICES AND ALLOW THE GENERATOR TO COOL DOWN

RECOMMENDED MAINTENANCE SCHEDULE		BEFORE EACH USE	AFTER 1ST MONTH OR 20 HRS	EVERY 3MTH OR 50 HRS	EVERY 6MTH OR 100 HRS	EVERY YEAR OR 300 HRS
Engine Oil (Page 2-13 & 24)	Check Level	X				
	Replace		X		X	
Air Filter (Page 20)	Check	X				
	Clean			X		
	Replace					X

RECOMMENDED MAINTENANCE SCHEDULE		BEFORE EACH USE	AFTER 1ST MONTH OR 20 HRS	EVERY 3MTH OR 50 HRS	EVERY 6MTH OR 100 HRS	EVERY YEAR OR 300 HRS
Spark Plug (Page 21)	Check/Clean/Regap				X	
	Replace					X
Idle Speed	Check/Adjust					X
Fuel Tank (Page 22)	Drain/Clean				X	
Fuel Filter	Inspect	X				
	Replace					X
Fuel Hose	Check	X				
Spark Arrester (page 22)	Clean				X	

NOTE: Maintenance should be performed more often under dusty conditions or operating under heavy load.

IMPORTANT GENERATOR MAINTENANCE TIPS:

- Drain the carburettor after each use and before storage to prevent it from clogging.
- **DO NOT** store the generator with fuel inside the tank for more than 2 months - fuel will go bad.
- Run the generator for at least 20 minutes every month to charge the battery and maximise the generators lifespan.

NOTE: Failure to properly maintain the generator will void the warranty.

AIR FILTER MAINTENANCE

Check every 50 hours of operation (refer to recommended maintenance schedule).

Routine maintenance of the air filter helps maintain proper airflow to the carburettor. Occasionally check that the air cleaner is free of excessive dirt.

TO INSPECT AND CLEAN THE AIR FILTER:

1. Loosen the screws to the right side maintenance cover. Remove cover and set aside

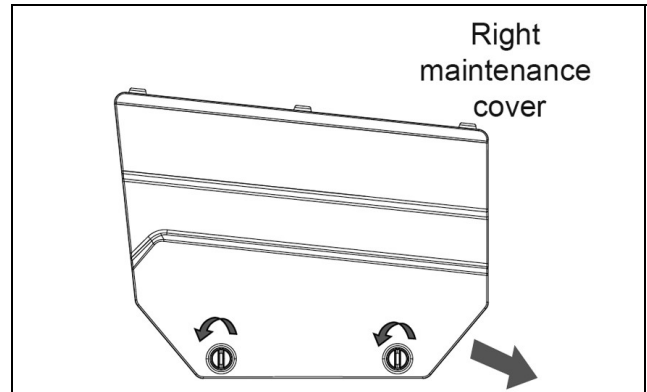

2. Unsnap the air filter cover clip, pull the cover down and off the unit (A).

3. Remove the air filter cover and set aside (B).

4. Remove the air filter (C).

5. Wash the air filter with warm, soapy water. Rinse and squeeze dry. Leave to dry thoroughly before reinstalling

6. Reinstall the air filter back into the unit and replace the cover.

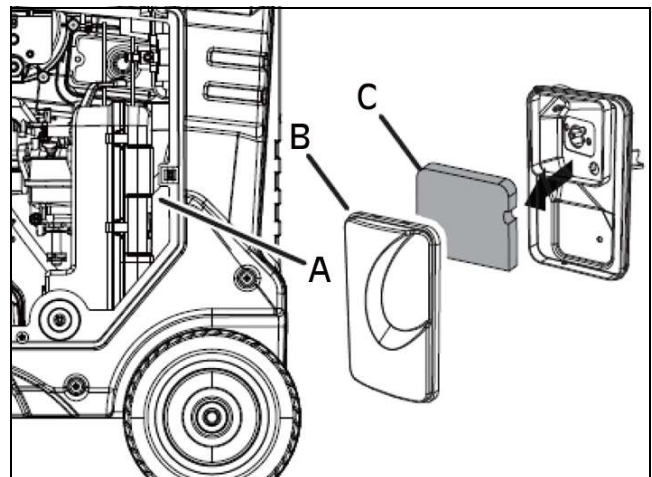

7. Reinstall the air filter unit back into the engine compartment and replace the maintenance cover.

NOTE: Running the engine with a dirty, damaged or missing air filter element can result in danger to the operator and cause the engine to wear out prematurely.

SPARK PLUG MAINTENANCE

The spark plug must be properly gapped and free of deposits in order to ensure proper engine operation. If the engine is hot, allow it to cool before servicing the spark plug (refer to recommended maintenance schedule).

TO INSPECT OR REPLACE THE SPARK PLUG:

1. Unscrew the maintenance cover knob and remove the cover from the side panel.
2. Remove the spark plug cap.
3. Use the included spark plug spanner to unscrew and then carefully remove the spark plug from the engine.

NOTE: There is limited space for the spanner to turn, use the arm to gain leverage to loosen the plug.

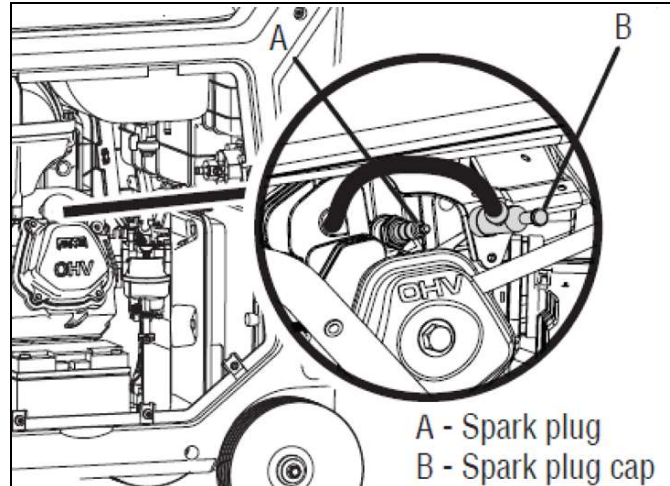

4. Visually inspect the spark plug. If it is cracked or chipped, or if the electrodes are worn or burned, discard it and replace with a new spark plug.
5. If re-using the spark plug, use a wire brush to clean any dirt from around the spark plug base, then re-gap the spark plug.

6. Measure the plug gap with a spark plug gap gauge. The gap should be 0.7 - 0.8mm (0.028 - 0.031in). Carefully adjust the gap if necessary.

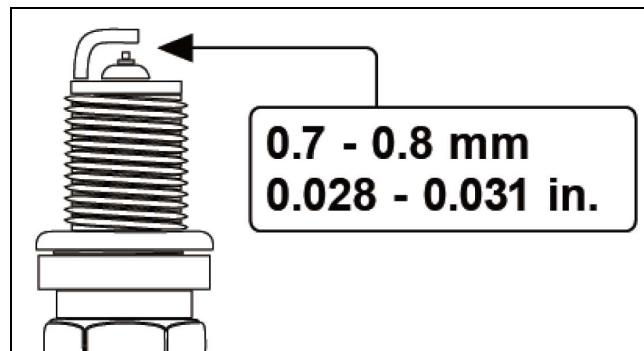

7. Screw the spark plug back into the spark plug hole using the spark plug spanner. **DO NOT** over-tighten the spark plug. Recommended tightening a spark plug is 1/2 to 4/3 of a turn (15ft/lb torque/20.33Nm) after the spark plug gasket contacts the spark plug hole.
8. Reinstall the spark plug cap and maintenance cover.

SPARK ARRESTOR MAINTENANCE

Inspect and clean the spark arrestor every 100 hours of operation (refer to recommended maintenance schedule). The spark arrestor is located outside the muffler, which gets very hot during operation. Allow the engine and the muffler to cool completely before servicing the spark arrestor.

TO INSPECT AND CLEAN THE SPARK ARRESTOR:

1. Remove the left maintenance cover, then loosen the jubilee clip holding the arrestor cover in place and remove the arrestor from its housing.

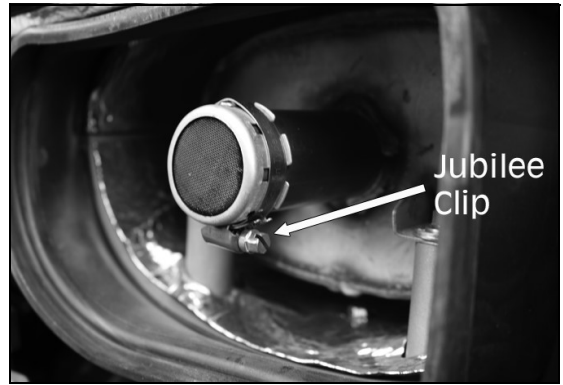

2. Use a brush to remove carbon deposits from the spark arrestor screen. Be careful to avoid damaging the screen. The spark arrestor must be free of breaks and tears. Replace the spark arrestor if it is damaged.
3. Install the spark arrestor in the reverse order of removal.

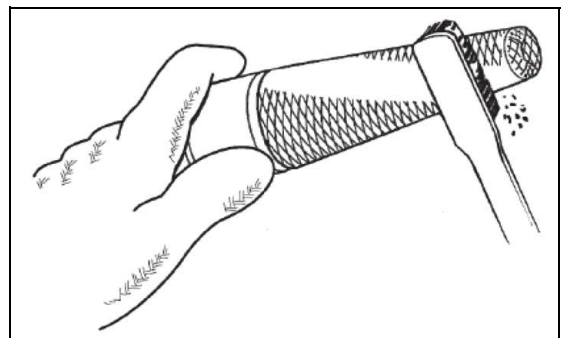

DRAINING THE FUEL TANK/CARBURETTOR

To help prevent gum deposits in the fuel system, drain the fuel from the tank and carburettor before storing.

TO DRAIN THE FUEL TANK & CARBURETTOR:

1. With the help of another person, place the generator on an elevated platform such as a table or workbench.

TO DRAIN THE FUEL TANK

1. Remove the fuel tank cap and fuel strainer.
2. Using a petrol hand pump, empty the fuel tank into an approved petrol container. Siphon the petrol by inserting the tip of the pump into the side of the pump guard.

NOTE: DO NOT use an electric pump

3. Reinstall the fuel strainer and replace the fuel tank cap.

TO DRAIN THE CARBURETTOR

1. Loosen the right maintenance cover knobs, and remove the cover from the side panel.
2. Turn the Main Switch to the Start/ Run position.
3. Remove the battery.
4. Prepare an approved petrol storage container and position it directly under the carburettor drain screw to catch the fuel.
5. Loosen the drain screw.
6. Allow the fuel to drain completely into the container.
7. Retighten the drain screw securely.
8. Turn the Main switch to the Off position.
9. Reinstall the maintenance cover

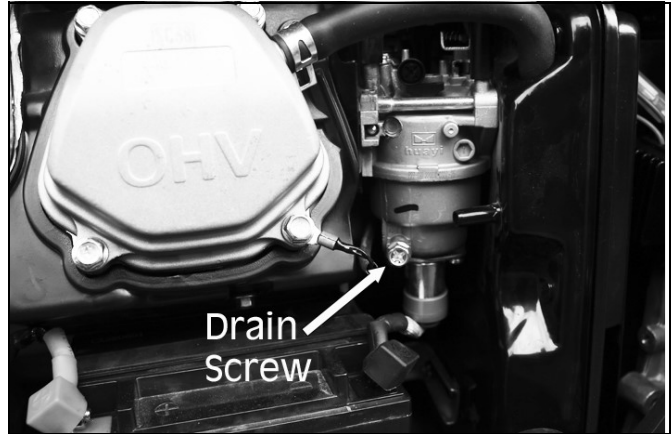

NOTE: Make sure to drain the carburettor before storing the generator for long periods of time.

DRAINING/CHANGING THE OIL

Change the oil more often if operating under heavy load or high ambient temperature. It is also necessary to drain the oil from the crankcase if it has become contaminated with water or dirt. Changing the oil when the engine is warm allows for complete drainage. Change the oil according to the recommended maintenance schedule on page 19.

TO CHANGE THE ENGINE OIL:

1. With the help of another person, place the generator on an elevated platform such as a table or workbench.
2. Loosen the screws of the left hand side maintenance cover, and remove the cover from the side panel.
3. Place a suitable container underneath the generator to catch the used oil.

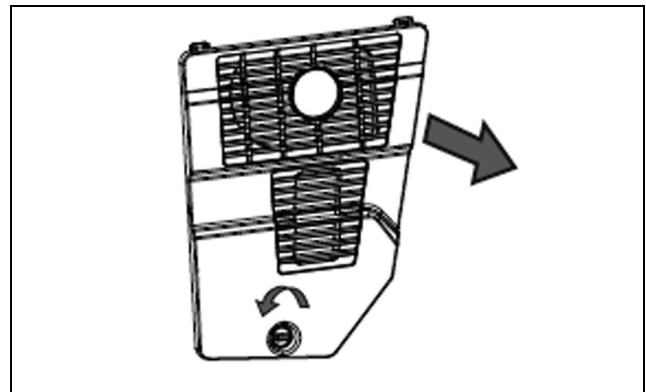

4. Reach under the generator and remove the black rubber seal located below the oil drain plug.
5. Remove the oil fill cap/dipstick.
6. Remove the other black rubber seal located in the front of the oil drain plug.
7. Use a spanner to remove the oil drain plug and allow the oil to drain completely.
8. Reinstall the oil drain plug after the oil has drained.
9. Reinstall the 2 black rubber seals.

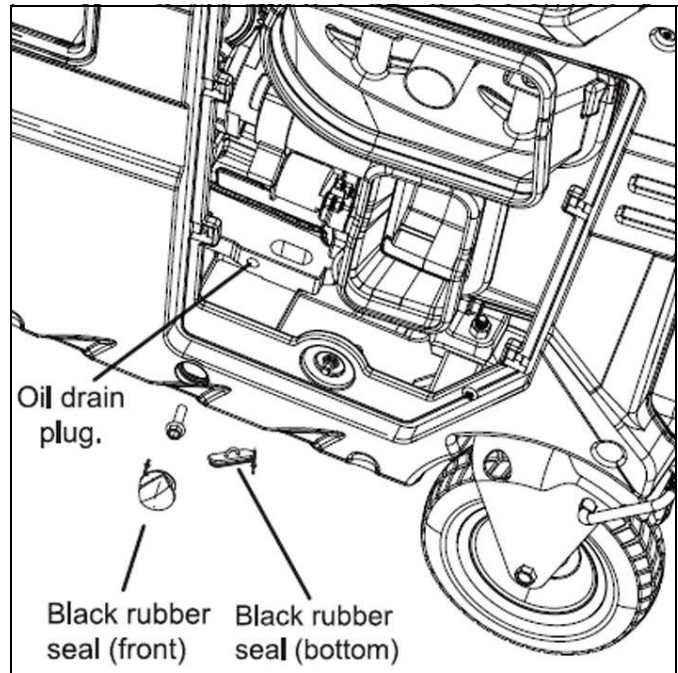

NOTE: NEVER dispose of used engine oil in general rubbish or down a drain. See local authority recycling for more information.

10. With the generator in a level position, refill the the engine with new oil. See section Add/Check Oil on page 12.
11. Reinstall the oil dipstick and tighten it securely. Wipe clean any oil spillage and reinstall the oil access cover.
12. Replace the maintenance cover.

TRANSPORTING THE GENERATOR

To prevent fuel spillage when transporting, be sure to perform the following:

1. Tighten the fuel cap and turn the vacuum relief valve to 'OFF'
2. Set the engine switch to 'OFF'.
3. Drain the fuel tank if possible, see section Draining the Fuel Tank/carburettor on pages 22-23.
4. Keep the generator upright. **NEVER** place the generator on its side or upside down - doing so will make it difficult to start next time.



WARNING: AVOID DIRECT SUNLIGHT INSIDE A VEHICLE. IF THE GENERATOR IS LEFT IN AN ENCLOSED VEHICLE FOR MANY HOURS, THE HIGH TEMPERATURE COULD CAUSE THE FUEL TO VAPORISE AND RESULT IN A POSSIBLE EXPLOSION.

STORING THE GENERATOR

Shut off the generator and allow the unit to cool to room temperature before storing it. **NEVER** place any type of storage cover on the generator while it is still hot. **DO NOT** obstruct any ventilation openings.

Follow the procedures below for properly storing your generator. We highly recommend running your generator once a month for 20 to 30 minutes. Plug in a small load to ensure there is proper power output.

FOR SHORT PERIODS (30 TO 60 DAYS)

NOTE: DO NOT store fuel for more than 2 months

- Drain the fuel tank and carburettor (see section Draining the Fuel Tank/ carburettor on pages 22-23).
- Disconnect the negative lead from the battery (see section Connecting the Battery on pages 14-15).
- Add fuel stabiliser. Follow the suggested portions and instructions for your preferred stabiliser. Run the engine for 15 to 20 minutes, allowing the fuel stabiliser to mix with the petrol and circulate through the carburettor, and then top off with fuel. Filling the fuel tank full reduces the amount of air in the tank and helps fight deterioration of the fuel.

FOR EXTENDED PERIODS (OVER 60 DAYS)

- Disconnect the negative lead from the battery (see section Connecting the Battery on pages 14-15).
- Drain the fuel tank and carburettor (see section Draining the Fuel Tank/ carburettor on pages 22-23). **NEVER** store the generator with fuel in the tank for more than two months.
- Change the engine oil (see section Draining and Changing the Oil on pages 23-24).

FOR 1 YEAR OR MORE

- Remove the spark plug, put a tablespoon of engine oil into the spark plug cylinder. Turn the engine slowly using the pull rope to distribute the engine oil. Reinstall the spark plug.
- Drain the fuel tank and carburettor (see section Draining the Fuel Tank/ carburettor on pages 22-23).
- Change the engine oil.
- After removal from storage, fill with fresh petrol.

NOTE: If storing petrol in a suitable container for later use, make sure the petrol has been treated with fuel stabilizer according to the stabilizer manufacturers instructions.



WARNING: STORE THE GENERATOR UPRIGHT IN A COOL AND DRY LOCATION, AWAY FROM SOURCES OF HEAT, OPEN FLAMES, SPARKS OR PILOT LIGHTS.

ENVIRONMENTAL RECYCLING POLICY



Through purchase of this product, the customer is taking on the obligation to deal with the WEEE in accordance with the WEEE regulations in relation to the treatment, recycling & recovery and environmentally sound disposal of the WEEE.

In effect, this means that this product must not be disposed of with general household waste. It must be disposed of according to the laws governing Waste Electrical and Electronic Equipment (WEEE) at a recognised disposal facility.

If disposing of this product or any damaged components, do not dispose of with general waste. This product contains valuable raw materials. Metal products should be taken to your local civic amenity site for recycling of metal products.

PRODUCT DISPOSAL

DO NOT dispose of used generator or parts with your household waste. This product contains electrical or electronic components that should be recycled under the WEEE regulations. Please take this product to your local recycling facility for responsible disposal to minimise its environmental impact.

DO NOT dispose of used oil or fuel in general waste or down a drain. Please see local authority recycling for more information.

SPECIFICATIONS

CLARKE part no 8877135		IG8000
Engine	Engine Model	SC460
	Fuel Type	Unleaded Petrol (E10)
	Displacement (cc)	459 (16HP)
	Start system	Electric, Remote Control & Hand Recoil
	Fuel tank capacity (L)	26
	Fuel consumption (L/Hr)	3.1
	Maximum run time @75% Load	8 hours 15 mins
	Engine oil type	SAE10W30
	Engine oil capacity (L)	1 Litre
	Battery	12V, 14Ah Lead Acid
	High Temperature Shut Down	80°C
Generator	Rated Frequency (Hz)	50
	AC Output Voltage (230V)	13A x 2, 32A x 1
	DC Output Voltage (V)	5V x 1 (USB) & 12V x 1
	Rated Running Power (W)	7000
	Max. Starting Power (W)	7500
	IP Rating	IP23M
Dimensions	Depth x Width x Height (mm)	610 x 770 x 755
	Weight (kg): Minus Fuel & Oil	114
Environmental	Sound pressure level	74 dB
	Sound power level	94 dB
	Guaranteed sound power level	97 dB
	Uncertainty factor	2.8 dB

TROUBLESHOOTING

PROBLEM	POSSIBLE CAUSE	SOLUTION
The generator fails to start	Battery not charged	Charge battery
	Engine switch is in the OFF position	Turn engine switch to the ON position
	No fuel	Fill fuel tank (see pages 13-14)
	Stale petrol or water in petrol	Drain entire system and refill with fresh fuel (see pages 22-23)
	Engine oil level is low	Engine is equipped with Low Oil Shutoff. If engine oil level is low, it must be filled before unit will start. Check engine oil level and fill if necessary (see pages 12-13)
	Fuel switch is in the OFF position	Turn fuel switch to the ON position
	Spark plug faulty, fouled, or improperly gapped	Replace spark plug (see page 21)
	Engine stored without treating or draining petrol, or refueled with bad petrol	Drain fuel. Refuel with fresh petrol (see pages 22-23)
Engine lacks power	Dirty fuel filter	Replace fuel filter or contact the CLARKE service department
	Dirty air filter	Check air filter element. Clean or replace as needed (see page 20)
Engine lacks power	Engine stored without treating or draining petrol, or refueled with bad petrol	Drain fuel. refuel with fresh petrol (see pages 22-23). If problem continues, contact the CLARKE service department
The generator is difficult to start	The air filter is dirty.	Clean the air filter (Page 20).

PROBLEM	POSSIBLE CAUSE	SOLUTION
AC receptacle does not work	OUTPUT indicator is OFF, and OVERLOAD indicator is ON	Check AC load (see pages 10-11). Stop and restart the engine. Check the cooling air inlet. Stop and restart the engine.
	AC Circuit protector has tripped	Check AC load and reset AC circuit protectors (see pages 9-11)
	GFCI system has activated (if used)	Reset the GFCI
	Item plugged in is defective	Try a different device.

If this does not solve your problem contact the CLARKE service department.

PARTS LISTS AND DIAGRAMS

MACHINE CORE COMPONENTS

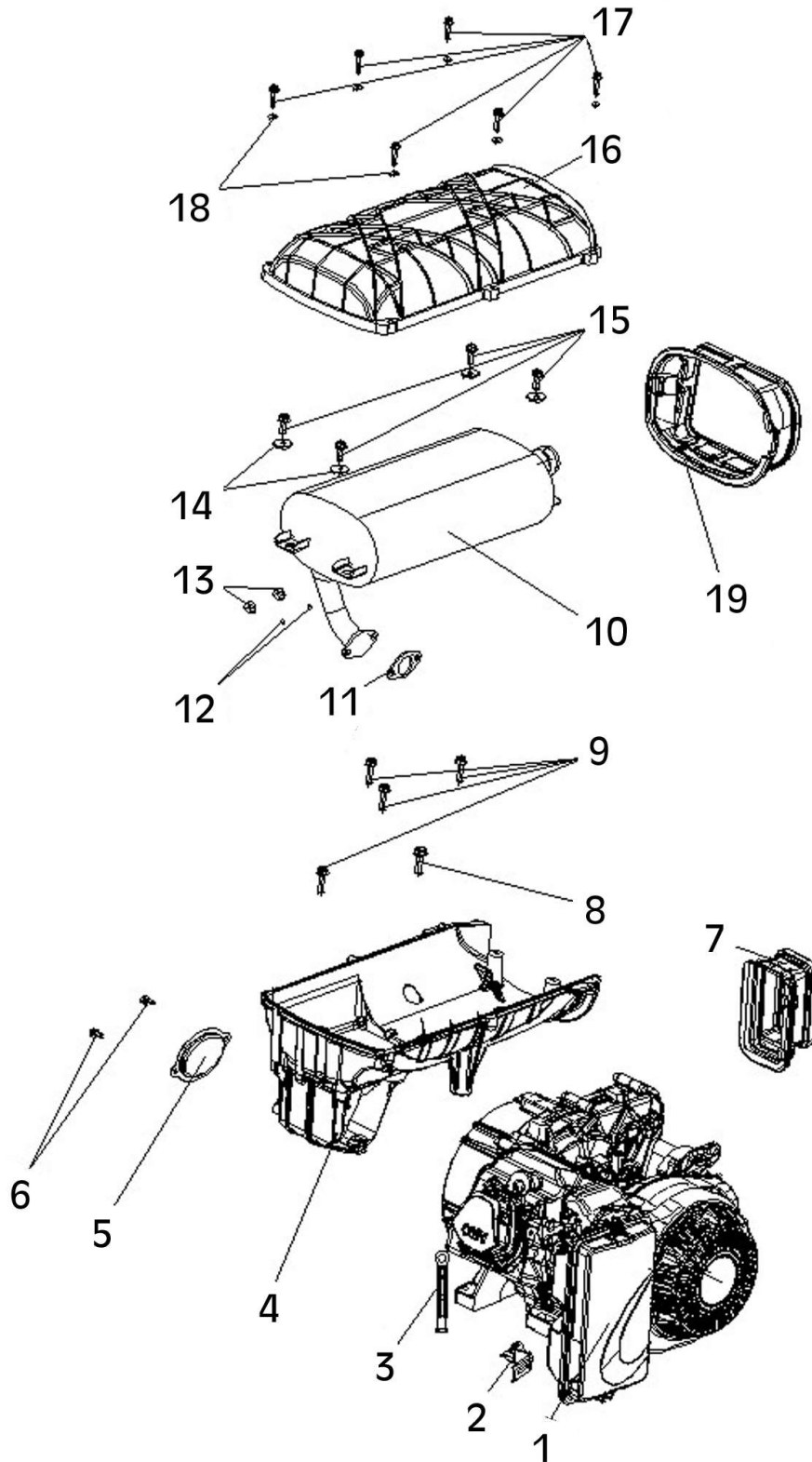

ITEM	DESCRIPTION	QTY
1	Engine	1
2	Air Filter Holder	1
3	Temperature Sensor	1
4	Muffler Exhaust Lower Hood Assembly	1
5	Muffler Lower Cover Plate	1
6	Hexagon Flange Bolt	2
7	Motor Exhaust Hood	1
8	Hexagon Flange Bolt	1
9	Hexagon Flange Bolt	4
10	Muffler Assembly	1
11	Muffler Washer	2
12	Spring Washer	2
13	Flange Nut	2
14	Washer	4
15	Hexagon Flange Bolt	4
16	Muffler Exhaust Upper Hood Assembly	1
17	Hexagon Flange Bolt	6
18	Washer	6
19	Muffler Exhaust Hood	1

BASE PLATE COMPONENTS

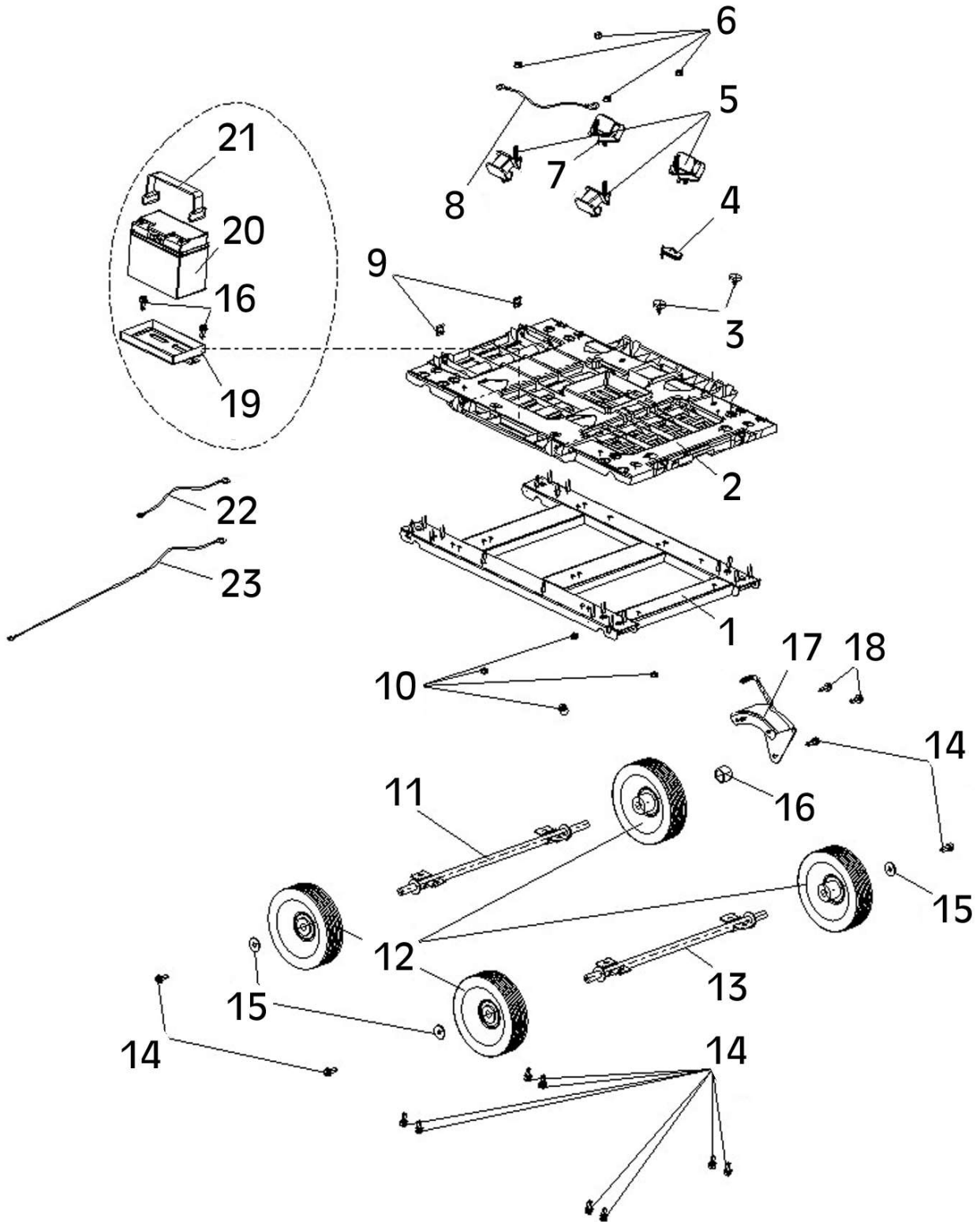

ITEM	DESCRIPTION	QTY
1	Support Plate	1
2	Hexagon Flange Bolt	1
3	Inverter Absorber Washer	2
4	Oil Plug	1
5	Shock Absorber	3
6	Flange Nut	4
7	Shock Absorber	1
8	Grounding Cable	1
9	Clamp Nut	16
10	Flange Nut	4
11	Axle	1
12	Wheel Assembly	4
13	Axle	1
14	Hexagon Flange Bolt	18
15	Washer	3
16	Bushings	1
17	Brake Components	1
18	Hexagon Flange Bolt	2
19	Battery Box	1
20	Battery	1
21	Battery Band	1
22	Negative Charging Cable	1
23	Positive Charging Cable	1

RACK COMPONENTS

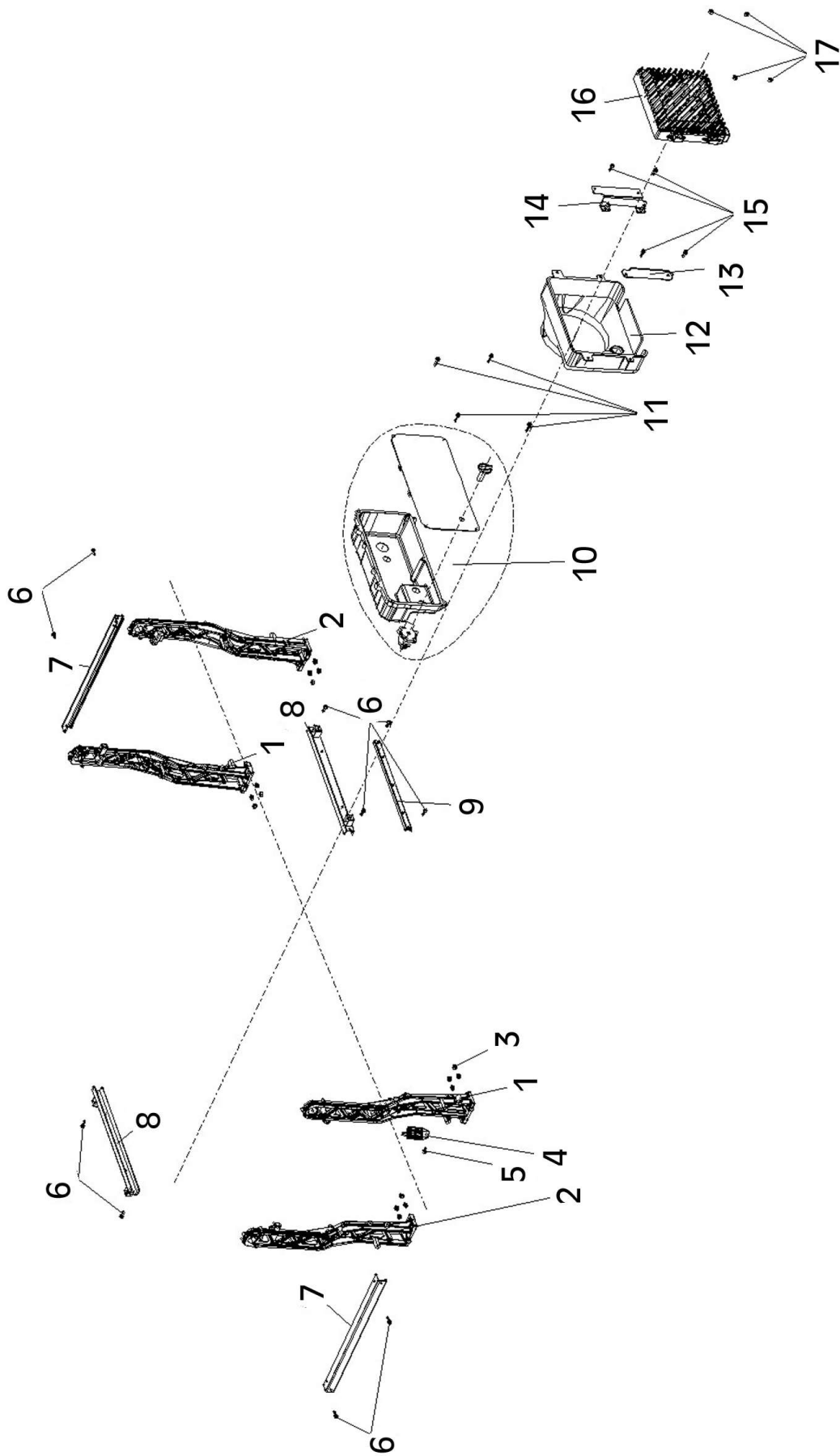

ITEM	DESCRIPTION	QTY
1	Bracket - Right	2
2	Bracket - Left	2
3	Flange Nut	16
4	DC Voltage Regulator	1
5	Hexagon Flange Bolt	1
6	Hexagon Flange Bolt	10
7	Right Frame Beam	2
8	Front/Back Upper Beam	2
9	Front Lower Beam	1
10	Control Panel Assembly	1
11	Hexagon Flange Bolt	4
12	Hood Assembly	1
13	Inverter Fixing Bracket - Left	1
14	Inverter Fixing Bracket - Right	1
15	Hexagon Flange Bolt	4
16	Inverter Parts	1
17	Flange Nut	4

OVERLAY COMPONENTS

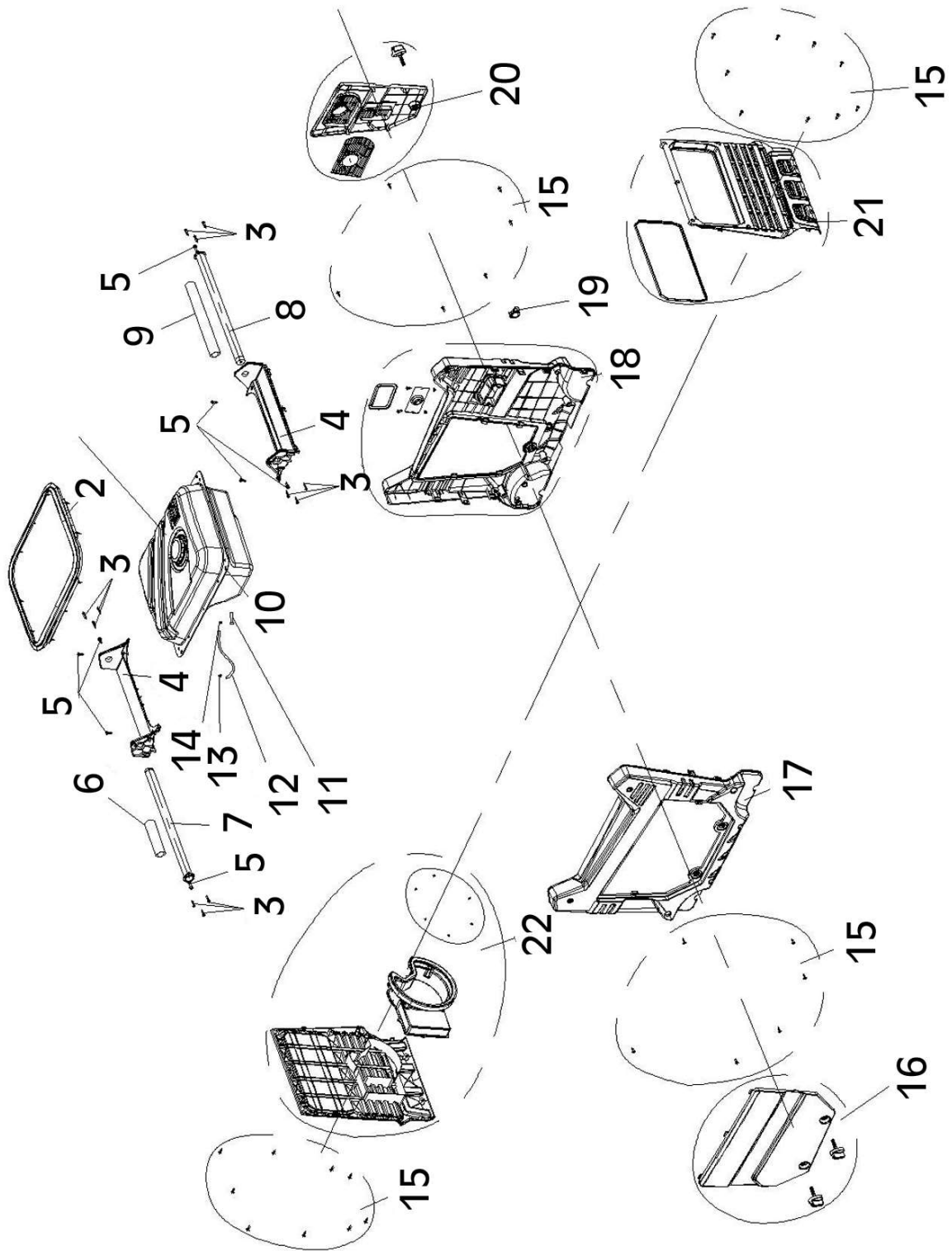

ITEM	DESCRIPTION	QTY
1	Fuel Tank Assembly	1
2	Fuel Tank Seal	1
3	Self Tapping Screw	12
4	Upper Cover Assembly	2
5	Hexagon Flange Bolt	8
6	Rubber Sleeve, Handle	1
7	Handle Assembly	1
8	Handle Assembly	1
9	Rubber Sleeve, Handle	1
10	Hexagon Flange Bolt	4
11	Filter Assembly	1
12	Fuel Pipe	1
13	Clamps	2
14	Clamps	1
15	Hexagon Flange Bolt	36
16	Left Window Plate Assembly	1
17	Left Panel Assembly	1
18	Right Panel Assembly	1
19	Oil Plug	1
20	Right Window Plate Assembly	1
21	Inverter Overlay Assembly	1
22	Motor Overlay Assembly	1

HANDLE COMPONENTS

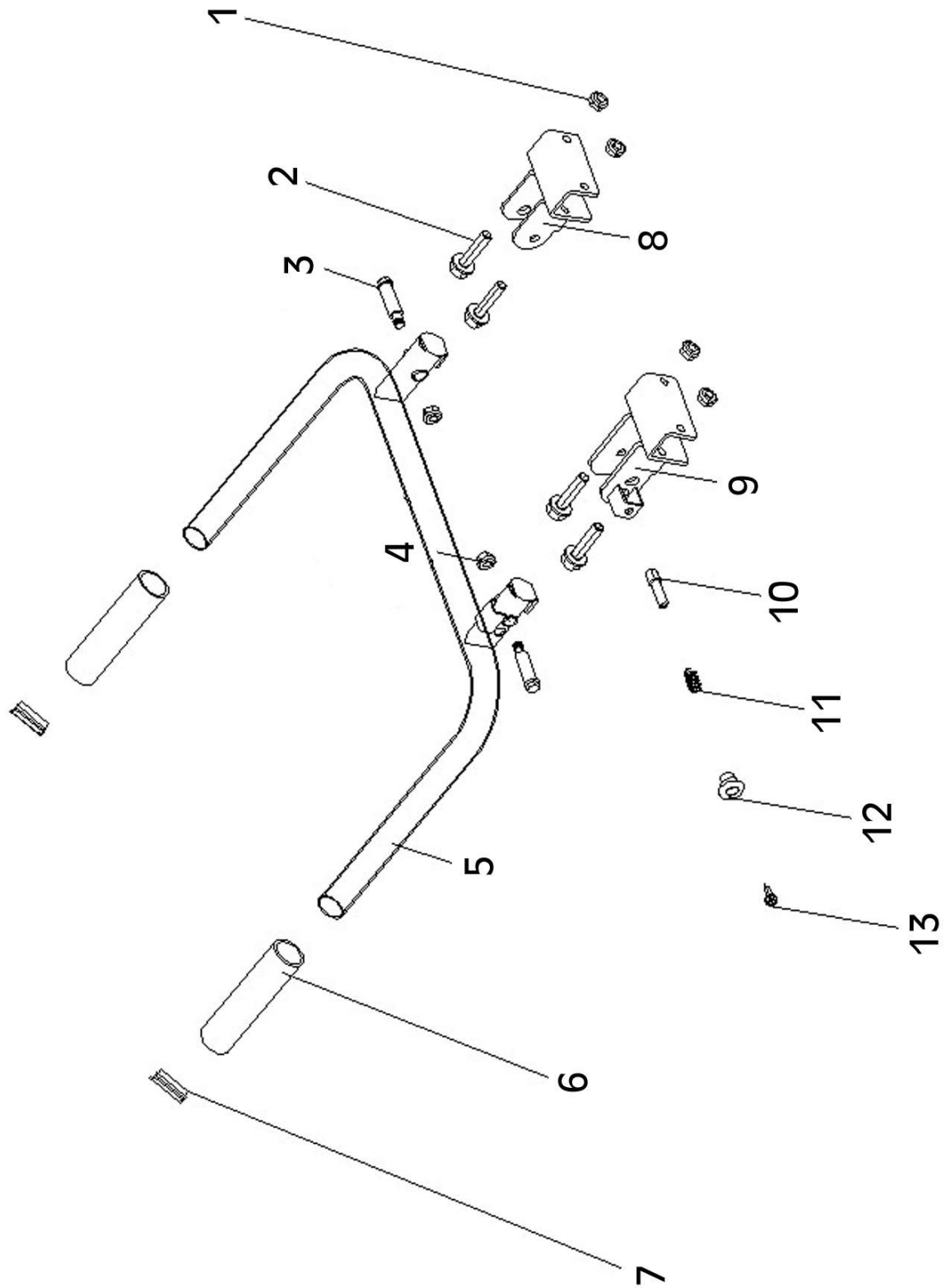

ITEM	DESCRIPTION	QTY
1	Nylon Nut	4
2	Hexagon Flange Bolt	4
3	Handle Fixing Pin	2
4	Flange Nut	2
5	Handle Assembly	1
6	Rubber Sleeve, Handle	2
7	Rubber Plug	2
8	Left Fixing Bracket, Handle	1
9	Right Fixing Bracket, Handle	1
10	Movable Pin	1
11	Fastening Spring	1
12	Handle Component	1
13	Hexagon Flange Bolt	1

DECLARATION OF CONFORMITY - UKCA



DECLARATION OF CONFORMITY

This is an important document and should be retained.

We hereby declare that this product(s) complies with the following legislation: The following standards have been applied to the product(s):

- Noise Emission in the Environment by Equipment for use Outdoors Regulations 2001 IEC 62321-4:2013+AMD1:2017, IEC 62321-5:2013, IEC 62321-6:2015, IEC 62321-7-2:2017, The Batteries and Accumulators (Placing on the Market) Regulations 2008 EN 55012:2007+A1:2009, EN ISO 8528-13:2016, IEC 62321-7-1:2015, IEC 62321-3-1:2013, The Electromagnetic Compatibility Regulations 2016 EN ISO 17075-1:2017, IEC 62321-8:2017, EN ISO 3744:1995, ISO 8528-10:1998
- The Supply of Machinery (Safety) Regulations 2008
- The Restriction of the Use of Certain Hazardous Substances in Electrical and Electronic Equipment Regulations 2012

The technical documentation required to demonstrate that the product(s) meet(s) the requirement(s) of the aforementioned legislation has been compiled and is available for inspection by the relevant enforcement authorities.

The UKCA mark was first applied in: 2023

Manufacturer:	Clarke International Ltd, Hemnall Street, Epping, Essex, CM16 4LG, United Kingdom	Notified Body:	Vericoert S.R.L. (ID Number: 1878), Via L. Masotti, 5 - Fornace Zarattini - 48124 Ravenna (RA), Italy
Product Description:	Generator	Assessment Procedure:	Annex VI of above noise legislation
Model Number(s):	IG8000	Measured LWA:	94 dB
Serial/Batch Number:	Refer to product/packaging label	Guaranteed LWA:	97 dB
Document Holder:	Alan Pond	Signed:	
Date of Issue:	05/09/2024		J.A Clarke Director

IG8000 UKCA Clarke DOC 090524

Page 1 of 1

DECLARATION OF CONFORMITY - CE



DECLARATION OF CONFORMITY

This is an important document and should be retained.

We hereby declare that this product(s) complies with the following legislation: The following standards have been applied to the product(s):

2000/14/EC	Outdoor Noise Directive	IEC 62321-4:2013+AMD1:2017, IEC 62321-5:2013, IEC 62321-6:2015, IEC 62321-7-2:2017,
2006/66/EC	Battery Directive	EN 55012:2007+A1:2009, EN ISO 8528-13:2016, IEC 62321-7-1:2015, IEC 62321-3-1:2013,
2014/30/EU	Electromagnetic Compatibility Directive	EN ISO 17075-1:2017, IEC 62321-8:2017, EN ISO 3744:1995, ISO 8528-10:1998
2006/42/EC	Machinery Directive	
2011/65/EU	Restriction of Hazardous Substances (RoHS) Directive	

The technical documentation required to demonstrate that the product(s) meet(s) the requirement(s) of the aforementioned legislation has been compiled and is available for inspection by the relevant enforcement authorities.



The CE mark was first applied in: 2023



Manufacturer:	Clarke International Ltd, Fitzwilliam Hall, Fitzwilliam Place, Dublin 2, Republic of Ireland	Notified Body:	Vericert S.R.L. (ID Number: 1878), Via L. Masotti, 5 - Fornace Zarattini - 48124 Ravenna (RA), Italy
Product Description:	Generator	Assessment Procedure:	Annex VI of above noise legislation
Model Number(s):	IG8000	Measured LWA:	94 dB
Serial/Batch Number:	Refer to product/packaging label	Guaranteed LWA:	97 dB
Document Holder:	Alan Pond	Signed:	
Date of Issue:	05/09/2024		J.A. Clarke Director

IG8000 CE Clarke DOC 090524

Page 1 of 1

CLARKE GENERATOR ACCESSORIES

<p>110V Yellow Generator Plug - GP32/1</p>	<p>230V Blue Generator Plug - GP32/2</p>	<p>20 Litre Fuel Can - Green</p>
		
<ul style="list-style-type: none"> • 110V 32A Generator Plug • Part No. 6160720 	<ul style="list-style-type: none"> • 230V 32A Generator Plug • Part No. 6160730 	<ul style="list-style-type: none"> • 0.8mm Thick Steel Construction • Locking Pin on Cap • Part No. 764990

<p>Oil Drainage Pan - COP8</p>	<p>SAE30 Motor Oil - SAE30</p>	<p>Fuel Can Spout - SP20L</p>
		
<ul style="list-style-type: none"> • 8 Litre Capacity. • Wide Pan with Pouring Lip • Part No. 7649850 	<ul style="list-style-type: none"> • 1 Litre • Part No. 3050852 	<ul style="list-style-type: none"> • Bayonet type fitting with rubber seal • Part No. 7650225

A SELECTION FROM THE VAST RANGE OF

Clarke®

QUALITY PRODUCTS



AIR COMPRESSORS
From DIY to industrial, Plus air tools, spray guns and accessories.

GENERATORS
Prime duty or emergency standby for business, home and leisure.

POWER WASHERS
Hot and cold, electric and engine driven - we have what you need

WELDERS
Mig, Arc, Tig and Spot. From DIY to auto/industrial.

METALWORKING
Drills, grinders and saws for DIY and professional use.

WOODWORKING
Saws, sanders, lathes, mortisers and dust extraction.

HYDRAULICS
Cranes, body repair kits, transmission jacks for all types of workshop use.

WATER PUMPS
Submersible, electric and engine driven for DIY, agriculture and industry.

POWERTOOLS
Angle grinders, cordless drill sets, saws and sanders.

STARTERS/CHARGERS
All sizes for car and commercial use.



PARTS & SERVICE: 0208 988 7400

Parts Enquiries
Parts@clarkeinternational.com

Servicing & Technical Enquiries
Service@clarkeinternational.com

SALES: UK 01992 565333 or Export 00 44 (0)1992 565335

Clarke® INTERNATIONAL Hemnall Street, Epping, Essex CM16 4LG
www.clarkeinternational.com